

60H2F系列闭环步进电机

60H2F Series hybrid servo motor

步距角 Step Angle	1.8°
绝缘电阻 Insulation Resistance	500V DC 100MΩ Min
绝缘强度 Dielectric Strength	500V AC 50Hz 2mA 1Minute
环境温度 Ambient Temperature	-20~+40°C
温升 Temperature Rise	80K Max
绝缘等级 Insulation Class	B

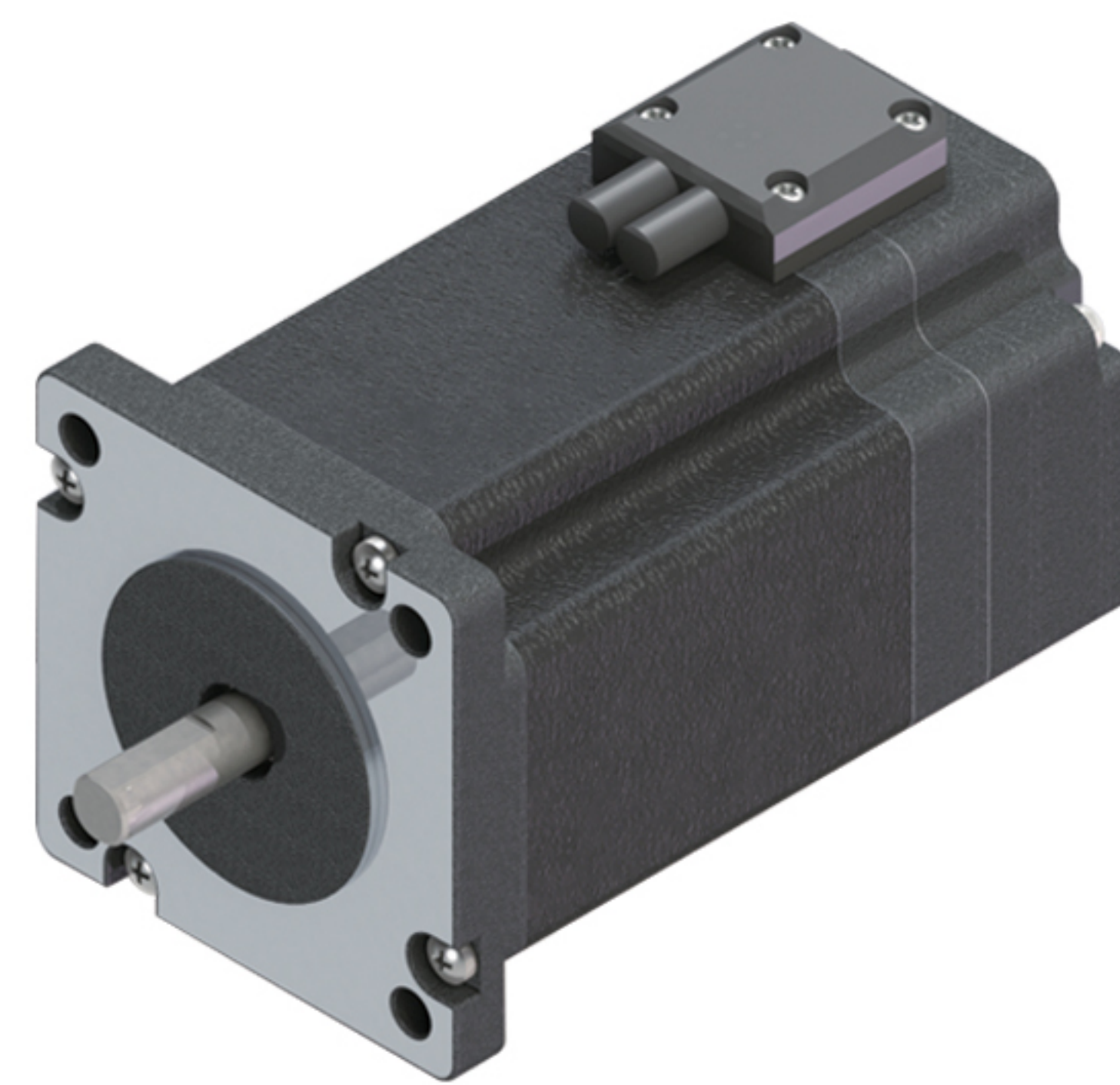

产品性能参数(Electrical specification):

型号	机身长度	额定电压	额定电流	绕组电参数 @20°C Typ.		静力矩		转子惯量		电机质量	
	mm			V	Amps	Ohms	mH	N.m	oz-in	g.cm ²	oz-in ²
60H2F77-E	77	4.5	5.0	0.9	2.6	1.80	255	450	2.5	0.83	1.8
60H2F101-E	101	5.5	5.0	1.1	2.4	2.80	397	580	3.2	1.05	2.3
60H2F111-E	111	6.0	5.0	1.2	2.2	3.30	468	900	4.9	1.40	3.1

以上产品可根据客户要求定制。
Above Products can be customized according to customer requirement.

外形尺寸 (Dimension):

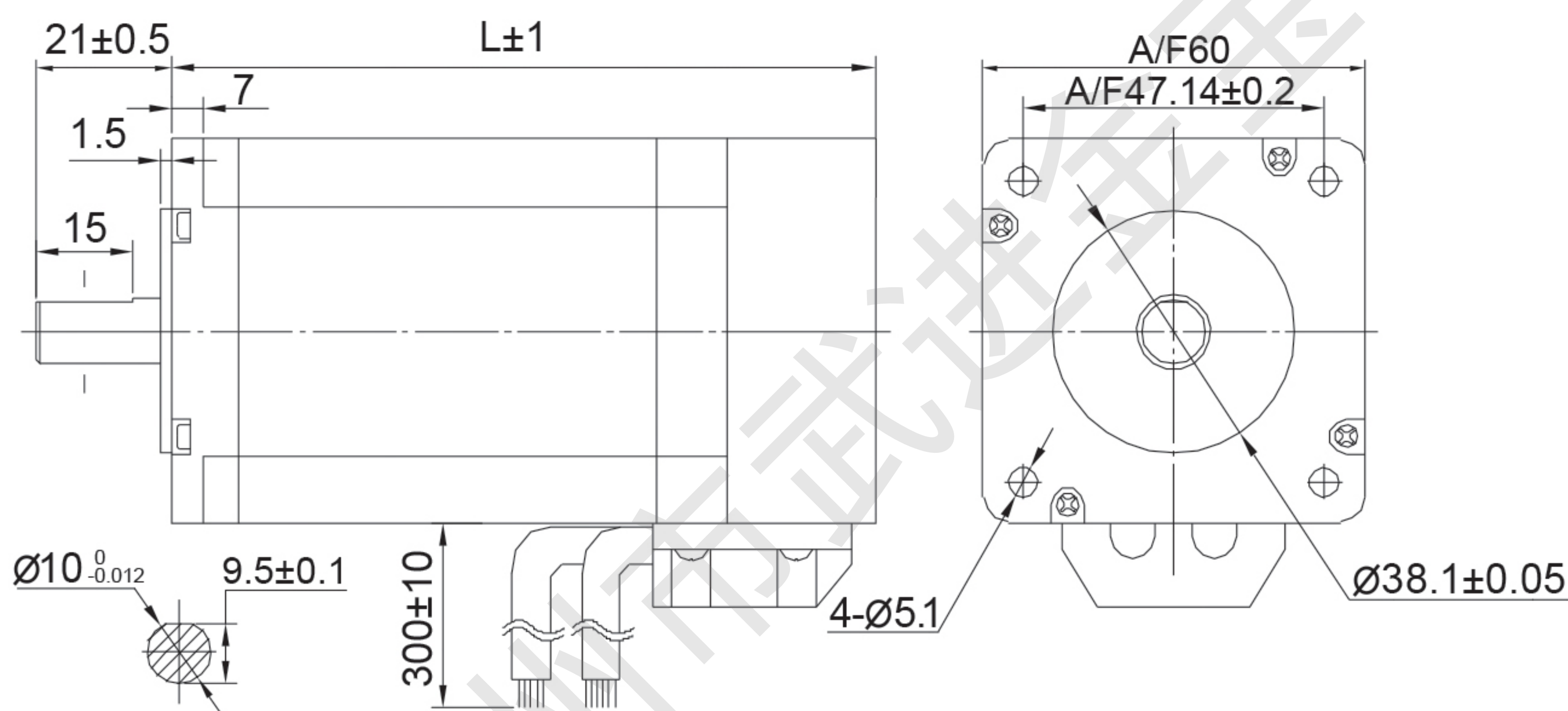

接线图 (Wiring Diagram):

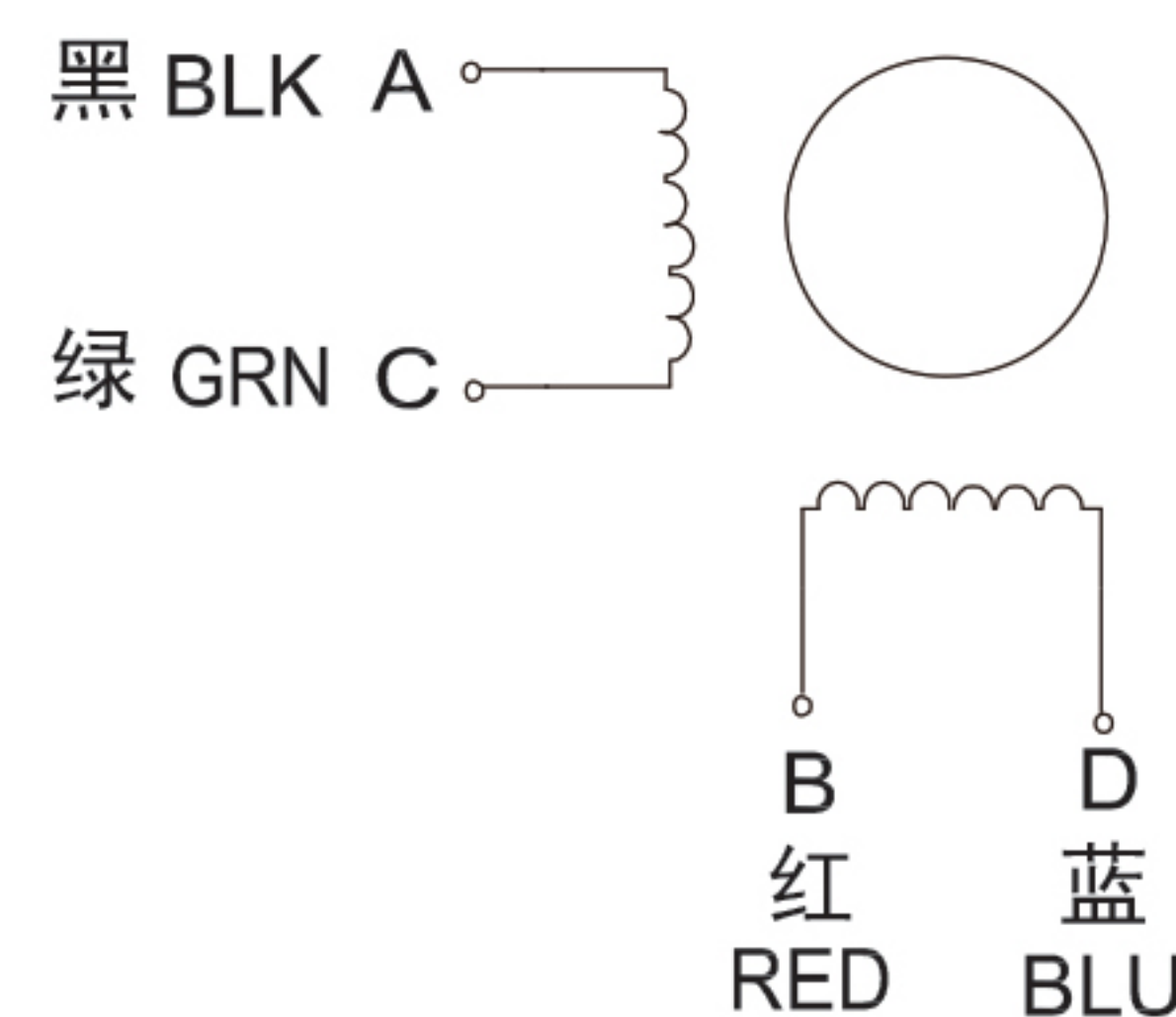

编码器引线定义:

颜色	红	黑	蓝	绿	黄	白
功能	+5V	GND	A+	A-	B+	B-

运行矩频特性 (Torque-frequency Characteristic):

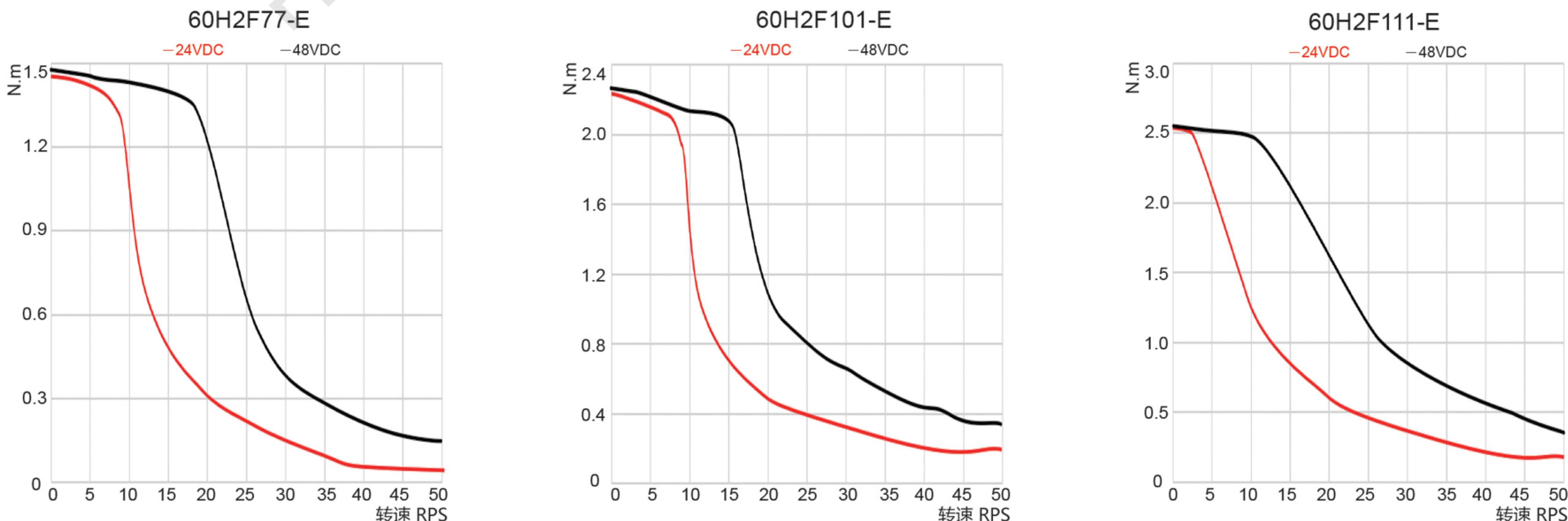

注意：装配时，须保证电机轴和负载轴的同轴，严禁敲打，以免损坏电机。
Note: When installing the motor, must ensure that the motor shaft and load shaft concentric, never hit it, so as not to damage the motor.