

# 130BYG250系列步进电机

## 130BYG250 Series stepping motor

步距角 Step Angle	1.8°
绝缘电阻 Insulation Resistance	500V DC 100MΩ Min
绝缘强度 Dielectric Strength	1000V AC 50Hz 2mA 1Minute
环境温度 Ambient Temperature	-20~+40°C
温升 Temperature Rise	80K Max
绝缘等级 Insulation Class	B

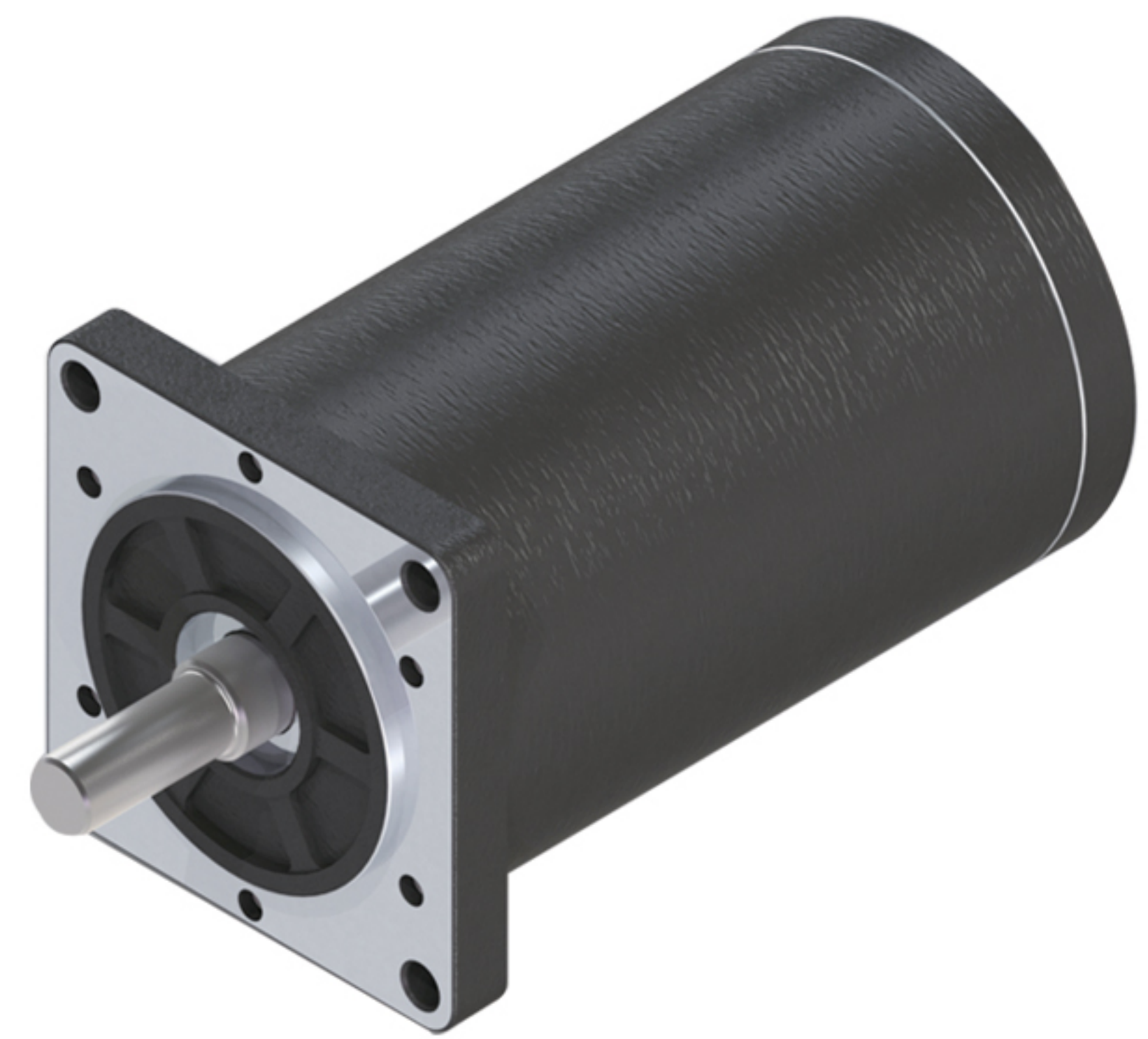

### 产品性能参数(Electrical specification):

型号 Model	运行电压 Operating Voltage	额定电流 Rated Current	电阻 Resistance	电感 Inductance	保持转矩 Holding Torque	空载频率 Noload Frequency	起动频率 Starting Frequency	重量 Weight	长度(L) Length
	VDC	A	Ω	mH	N.m	Hz	Hz	kg	mm
130BYG250	80-325	6	0.75	12.6	25	25000	2300	13.3	173
130BYG250A	80-325	6	0.83	13.2	30	25000	2300	18	229
130BYG250B	80-325	7	0.73	11.7	40	23000	2200	19	257
130BYG250C	80-325	7	0.66	10	50	23000	2200	22.5	285

以上产品可根据客户要求定制。  
Above Products can be customized according to customer requirement.

### 运行矩频特性 (Torque-frequency Characteristic):

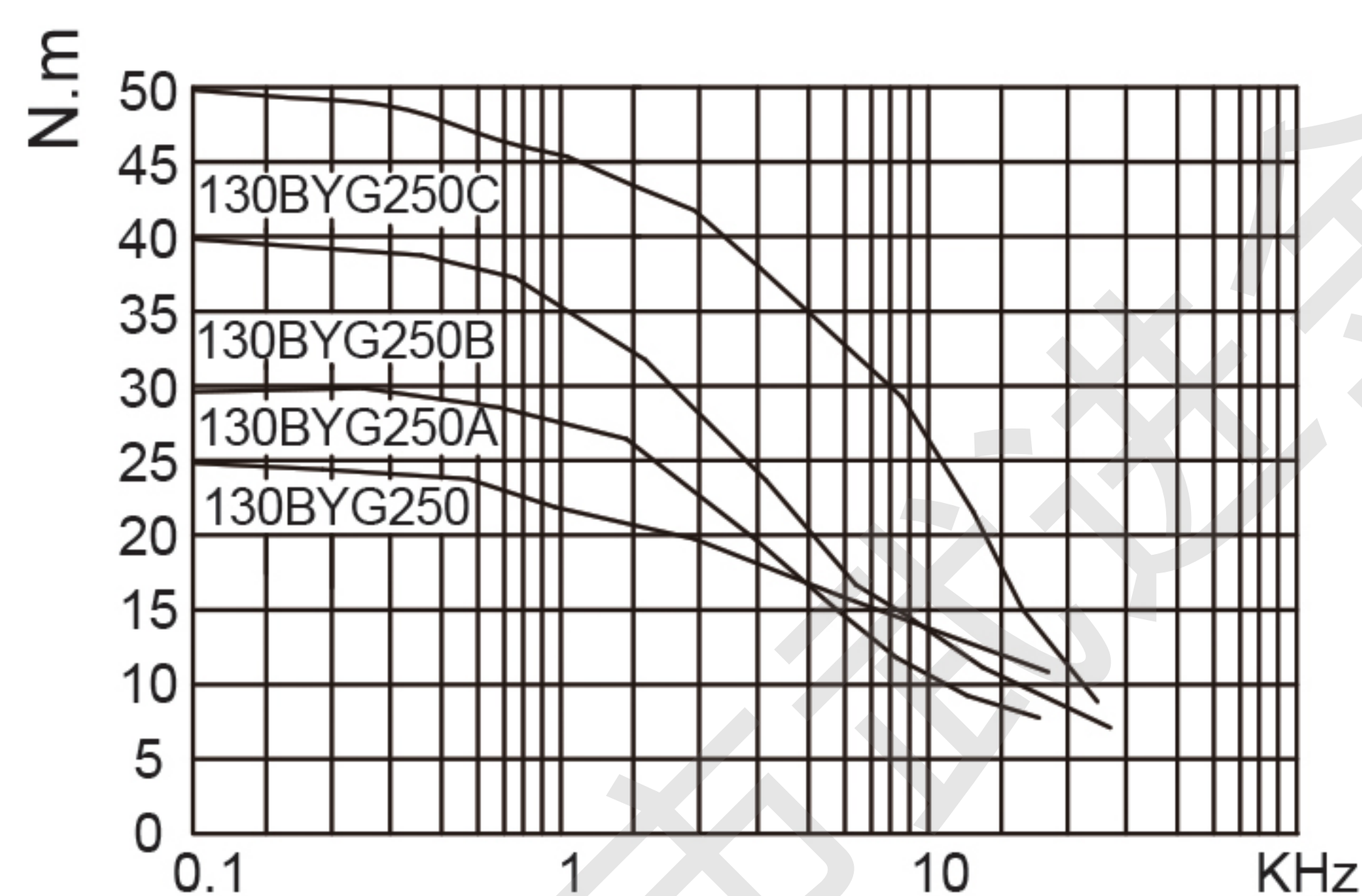

### 接线图(Wiring Diagram):

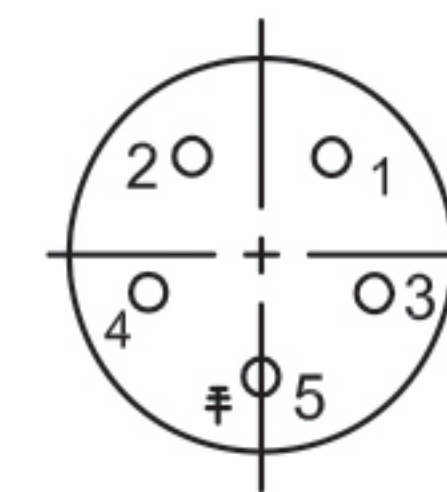

五芯插座  
Five Pins Socket

A	A'	B	B'	PE
1	2	3	4	5

### 外形尺寸 (Dimension):

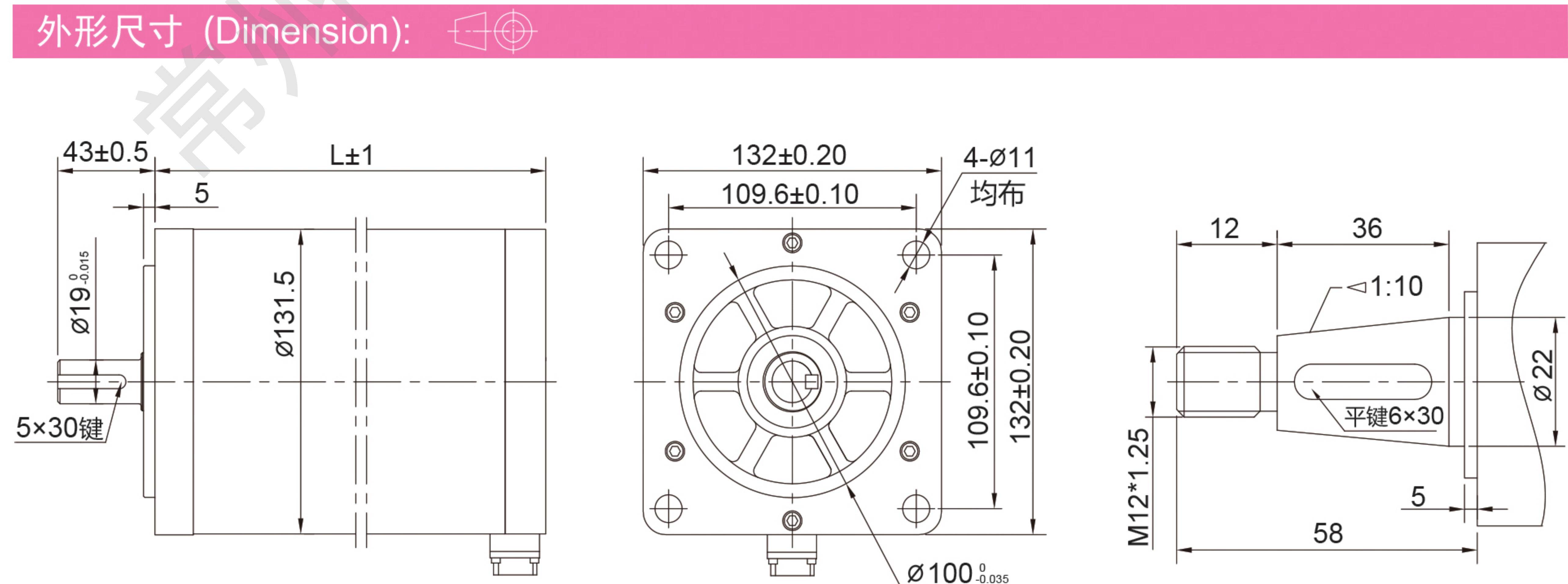

注意：装配时，须保证电机轴和负载轴的同轴，严禁敲打，以免损坏电机。  
Note: When installing the motor, must ensure that the motor shaft and load shaft concentric, never hit it, so as not to damage the motor.